

Planning of Gas Detection Systems

Between Transmitter and
Central Controller



Preface and Contents

This brochure is a guide for the planner and installer of Polytron gas detection systems.

It gives a number of answers for recurring questions emerging during the installation of such systems, e.g. the electrical connection of Dräger transmitters to a central controller like Polytron or Regard, respectively to any controller system. This is why we called it "Between Transmitter and Central Controller".

This brochure does not, under any circumstance, replace the respective operating manuals, however it is a supplement with tips and tricks and additional information.

Dr. Wolfgang Jessel
January 2003

Overview of Dräger Transmitters	3
1. The 2-wire principle	4
2. The 2-wire transmitters Polytron 1 and Polytron L	6
2.1 Polytron 1 for the non-hazardous area	6
2.2 Polytron 1 for the hazardous area	7
2.3 The 2-wire transmitter Polytron TX	7
3. Intrinsic Safety (I.S.) and Safety Barriers	8
3.1 Active safety barriers	8
3.2 Safety barriers with galvanic isolation	9
3.3 Safety relevant data of a safety barrier	10
3.4 The installation of a safety barrier	10
4. The 2-wire transmitter Polytron 2	11
4.1 Polytron 2 in a hazardous, classified area	11
5. The 3-wire and 4-wire principle	12
6. The Polytron 3-wire transmitters	14
6.1 Polytron FX	14
6.2 Polytron Ex	14
6.3 Polytron IR Ex	14
6.4 Polytron IR, Polytron 2 XP Ex und Polytron 2 XP Tox	15
7. Polytron transmitter and programmable logic controller systems	16
8. Digital Communication	17
8.1 HART Communication	17
8.2 RS 485 Communication	18
9. Cables, resistance and characteristics	19
10. The Polytron Sampling Unit	20

Overview of Dräger Transmitters

Product	Electrical connection	Classification	Category
Polytron 1	2-wire transmitter, 4 to 20 mA	EEx ia IIC T4/T6	II 2G
Polytron L	2-wire transmitter, 4 to 20 mA	EEx ia IIC T4	II 2G
Polytron TX	2-wire transmitter, 4 to 20 mA	EEx d IIB+H2 T5/T6 Class I, Div 1, Groups C, D	II 2G
Polytron 2	2-wire transmitter, 4 to 20 mA, HART	EEx ia IIC T4/T6	II 2G
Polytron FX	3-wire transmitter, 4 to 20 mA	EEx d IIC T4/T6 Class I, Div 1, Groups B, C, D	II 2G
Polytron Ex	3- / 4-wire transmitter, 4 to 20 mA	EEx me [ib] IIC T4	II 2G*)
Polytron Ex-R	3- / 4-wire transmitter, 4 to 20 mA	EEx me [ib] IIB T4	II 2G*)
Polytron IR Ex, IR CO ₂	3- / 4-wire transmitter, 4 to 20 mA	EEx me [ib] d IIB+H2 T4	II 2G
Polytron SE Ex	Wheatstone semi bridge	EEx de IIC T4/T5/T6	II 2G
Polytron IR	3-wire transmitter, 4 to 20 mA, HART, RS 485	EEx d [ia] IIC T5	II 2G
Polytron 2 XP Tox	3-wire transmitter, 4 to 20 mA, HART, RS 485	EEx d [ia] IIC T6 Class I, Div 1, Groups B, C, D	II 2G
Polytron 2 XP Ex	3-wire transmitter, 4 to 20 mA, HART, RS 485	EEx d IIC T4/T6 Class I, Div 1, Groups B, C, D	II 2G
Polytron Pulsar	Receiver: 3-wire transmitter, 4 to 20 mA	EEx d [ia] IIC T5/T6	II 2GD

The table gives a short overview of the Dräger transmitters, their electrical connection and classification.

For all transmitters the equipment category is II 2G according to directive 94/9/EG (ATEX 100a), i.e. the devices are suitable for hazardous areas classified as Class I (combustible gases and vapors) Zone 1 and Zone 2, however not Zone 0. An exception is Polytron Pulsar, which may also be used in Class II (combustible dusts), Zone 21 and 22, however not the Zone 20.

The table only shows the optical receiver of the Open-Path-System Polytron Pulsar, not the sender. The receiver is compatible to the described 3-wire transmitters.

All but one of the instruments are called transmitters, i.e. devices which transform the measured gas concentration into an electrical standard signal. Only Polytron SE Ex is not a transmitter. It will be called sensing head, because it is part of a Wheatstone bridge circuit (SE = semi bridge) and does not contain any electronics.

*) EC-Type examination certificate pending

1. The 2-wire principle

The main attribute of a 2-wire transmitter is the low power consumption under normal operation. It needs less than 4 mA to run. Only then power supply and output signal can use the same wiring.

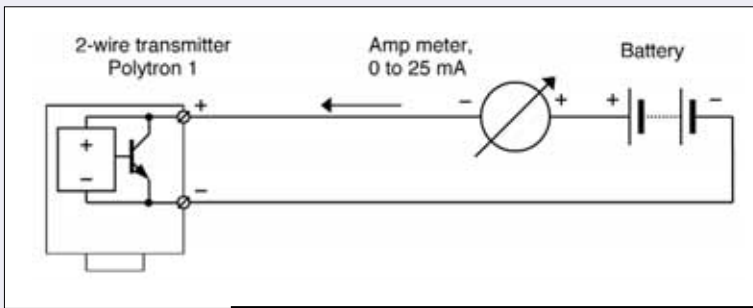

The figure shows a typical 2-wire circuit valid for every 2-wire transmitter. The electronics of the Polytron 1 transmitter needs a supply voltage of only 8 V, which is transformed internally to a dual, very stable voltage of ± 2.5 V. This voltage is sufficient to run the potentiostat- and amplifier-circuit, as well as to drive the display and the output-transistor. All this at a current of less than 2 mA. This does not change, even if the gas transducer (the electrochemical sensor) produces a higher signal when gas is present:

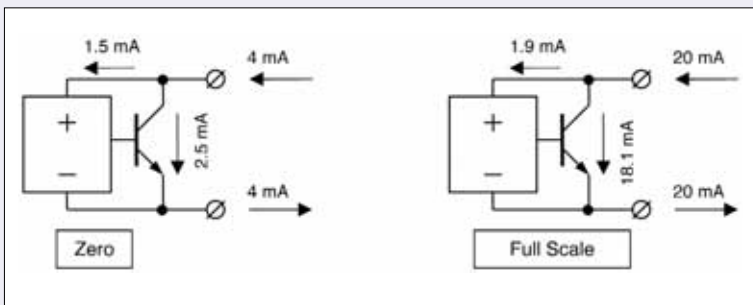

If the transmitter is calibrated, and no gas is present, it will display 'zero'. In order for the Ampere-Meter to show a current of 4 mA, the output-transistor has to 'open a bid', and draw enough current out of the supply line, so a total current of 4 mA is flowing. At 'full scale' (measured value equals full scale value) the current drain of the electronics is a little higher (in the example above, it increases from 1.5 to 1.9 mA), and the electronics of the output-transistor opens (i.e. reduces its contact resistance) only so far that 18.1 mA are flowing, hence a total current of 20 mA is flowing through the line.

The 4 to 20 mA current loop

There are a couple of advantages to the 4 to 20 mA current loop, which is well established in the field of industrial measurement instrumentation. First, the current loop is not only of low resistance, hence less prone to interferences compared to voltage-signals, but it also compensates the intrinsic resistance of the wiring (up to an upper limit). Second, the 'zero' of a 4 to 20 mA current loop is a 'life-zero', i.e. a device fault or not-connected/cut wiring is reliably recognized. An absolute necessity for safety equipment. The electronics design allows to recognize a failure of the device (e.g. missing sensor) and will immediately change the output signal to 3 mA. If the wiring is cut, no current is flowing (0 mA). Both states will generate a signal, not a measurement signal, which must be interpreted as fault.

Since the 4 to 20 mA has an upper limit, a value above 20 mA may not be interpreted as a measurement signal either. This can only mean, that the gas concentration exceeds the maximum range or a short circuit, meaning a fault. However the short circuit current must be limited on the controller side via a protective resistor (or by a fuse) to a meaningful value.

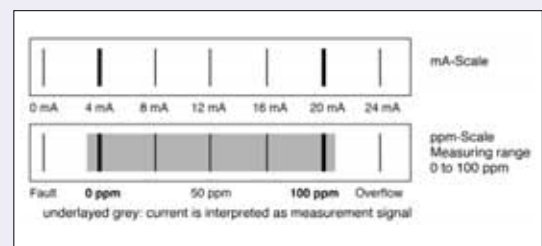

The recommendation by NAMUR, NE 43, defines all currents of less than 3.6 mA or higher than 21 mA as fault. Whereas the measurement signal, including underrange and overrange, lies between 3.8 and 20.5 mA:

Fault	i_A	$0 \leq i_A \leq 3.6 \text{ mA}$
Measurement signal	i_M	$3.8 < i_M < 20.5 \text{ mA}$
Fault	i_A	$i_A \geq 21 \text{ mA}$

For Example: the full scale value of a transmitter is 100 ppm, then 1 mA correlates to a gas concentration of $100/16 = 6.25$ ppm.

Cable length and maximum load

For operation, a 4 to 20 mA transmitter needs a certain minimum voltage U_{\min} . At this voltage, it must be possible to draw a current of more than 20 mA (as a value for our calculations we use $I_{\max} = 25 \text{ mA}$). Since the transmitter will be supplied with a voltage U_0 by the central controller, the maximum resistance R_{\max} of the current loop can be calculated as:

$$R_{\max} = R_{L \max} + R_{\text{in}} + R_S = \frac{U_0 - U_{\min}}{I_{\max}}$$

where the total loop resistance is determined by adding up the resistance of the wires R_L and the impedance R_{in} of the input circuit, including any protective resistor R_S .

The maximum cable length L can be calculated from the maximum loop resistance $R_{L \max}$, the specific resistance ρ of the wire-material and the cross-section A of the wire.

$$L = \frac{1}{2} \cdot \frac{A}{\rho} \cdot R_{L \max}$$

If the cross-section A is given in mm^2 and the max. loop resistance in Ohm, using $\rho = 0.018 \text{ Ohm} \cdot \text{mm}^2/\text{m}$ for copper, the cable length L in meter results to:

$$L = 27.7 \cdot A \cdot R_{L \max}$$

Example:

Polytron 1 ($U_{\min} = 8 \text{ V}$) connected to a Polytron Channel Card ($R_{\text{in}} = 50 \text{ Ohm}$, $R_S = 150 \text{ Ohm}$), supply voltage $U_0 = 18.5 \text{ V}$, and the maximum loop resistance is (see example below) 220 Ohm. If a 2-wire cable should be used, with a cross-section of $A = 0.75 \text{ mm}^2$, the cable length (distance between transmitter and central controller) may not exceed

$$L = 27.7 \cdot 0.75 \cdot 220 = 4570 \text{ m, (approx. 4.5 km)}$$

Note: This calculation is only valid, if the transmitter is not used in a hazardous, classified area, and no safety barrier is installed.

Example:

Polytron 1 ($U_{\min} = 8 \text{ V}$) connected to a Polytron Channel Card ($R_{\text{in}} = 50 \text{ Ohm}$, $R_S = 150 \text{ Ohm}$), supply voltage $U_0 = 24 \text{ V}$:

$$R_{L \max} = \frac{U_0 - U_{\min}}{I_{\max}} - R_{\text{in}} - R_S = \frac{24 - 8}{0.025} - 50 - 150 = 440 \text{ Ohm}$$

If the the power for the Polytron Channel Card is supplied by a battery (e.g. UPS), the transmitter will only be supplied with 18.5 V (worst case scenario where the voltage is 24 V - 20%, i.e. 19.2 V, minus 0.7 V voltage drop on the diode). Thus the maximal permissible loop resistance is:

$$R_{L \max} = \frac{U_0 - U_{\min}}{I_{\max}} - R_{\text{in}} - R_S = \frac{18.5 - 8}{0.025} - 50 - 150 = 220 \text{ Ohm}$$

In case of a short circuit, the protective resistor R_S limits the current to maximal

$$I = \frac{U_0}{R_S + R_{\text{in}}} = \frac{18.5}{200} = 0.0925 \text{ A} = 92.5 \text{ mA}$$

If the short circuit is at the input of the Polytron Channel Card; otherwise the additional resistance of the wires will reduce the short circuit current even further.

2 ■ The 2-wire transmitters Polytron 1 and Polytron L

The Polytron 1 transmitter is a so-called field measuring transducer, which transforms a measured gas concentration into a 4 to 20 mA signal. When used without a safety barrier, Polytron 1 may only be used in non-hazardous areas. When connected to an appropriate safety barrier, Polytron 1 can be installed in a hazardous area, classified as Zone 1 and Zone 2. Under certain circumstances (depending on the national regulations) a safety barrier does not need to be installed if the area is classified as Zone 2.

The installation in Zone 0 is not permissible. The gas category II 2G, according to directive 94/9/EC (ATEX), will undoubtedly tell the user that the transmitter is approved for the installation in Zone 1 and Zone 2, however not in Zone 0.

2.1 Polytron 1 for the non-hazardous area

The transmitter Polytron 1 can be operated with a supply voltage between 8 and 28 V. For central controllers, which are designed to be used with the transmitter (e.g. Polytron, Regard, QuadGard, etc.), the supply voltage is available at the terminals of the channel card (so-called transmitter feed). The evaluating circuit is always the same. The measuring current runs through the resistor R_{in} and produces a proportional voltage drop, which is amplified in the measuring amplifier. The resulting voltage is used to display the measured value and to create alarms, using switching amplifiers:

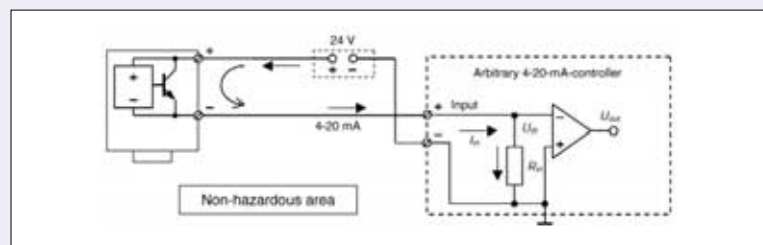
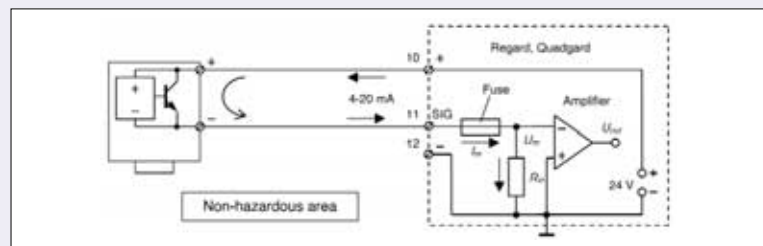
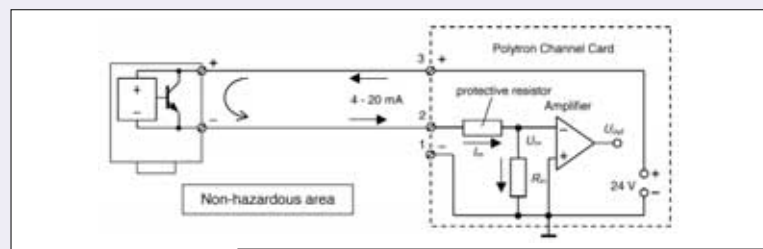

If a central controller without transmitter feed is used to operate the 2-wire transmitter (e.g. any programmable logic controller with 4 to 20 mA input), the transmitter must be connected to an external 24 V power supply (or an appropriate battery). While the positive pole of the power supply is connected directly to the positive pole of the transmitter, the minus pole of the power supply is connected to the negative input-terminal of the 4 to 20 mA input at the controller:

2.2 Polytron 1 for the hazardous area

The Polytron 1 transmitter is an explosion protected electrical apparatus designed in protection type “intrinsically safe”, marked as “EEx ia IIC T4/T6”.

In a few words, intrinsic safety is a protection technique ensuring that in case of one fault (“ib”) or even two independent faults (“ia”) neither hot surfaces, nor sparks can occur which might ignite a mixture of a given flammable gas/air mixture. Contrary to other protection techniques, not only the device but the complete circuit is intrinsically safe. This intrinsically safe circuit must be separated from the non-intrinsically safe circuit of the controller by a so-called safety barrier. When selecting a safety barrier, it has to be taken into account that for Polytron 1 or Polytron L the following electrical parameters may not be exceeded:

$$U_{\max} = 28 \text{ V}, P_{\max} = 660 \text{ mW}$$

Dräger recommends the safety barrier GHG 1169 110 V0 (ABB). The corresponding parameters ($U_{\max} = 19.2 \text{ V}$, $P_{\max} = 648 \text{ mW}$) are lower than the maximum allowed values for Polytron 1. The safety barrier must be earthed (PE) or connected to PA, and so is the shielding.

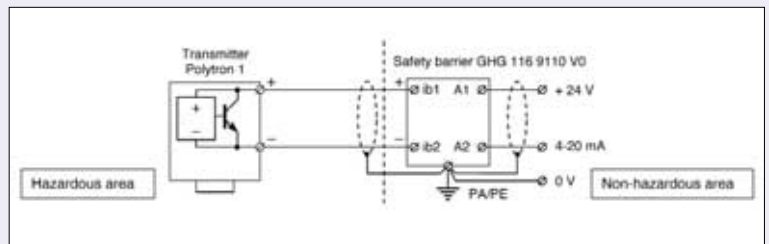

Using an intrinsically safe galvanic isolator earthing makes no sense. The shielding of the cable at the intrinsically safe side has to be connected to a defined potential, e.g. the minus pole. The shielding between I.S. galvanic isolator and central unit should be connected to the earth potential of the central unit (PE).

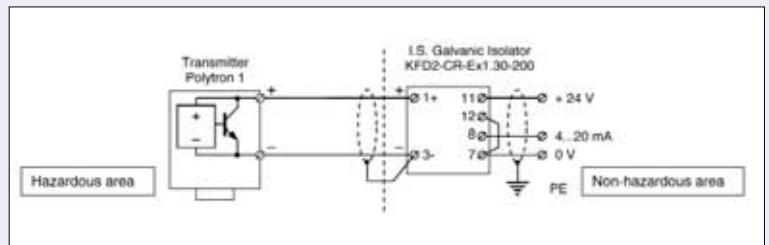

The following safety barriers are suitable for Polytron 1:

Manufacturer	Type	isolated yes/no	C_{\max} in nF		L_{\max} in mH		R_{\max} per core
			IIC	IIB	IIC	IIB	
Stahl	9005/01-245/060/00	no, [ib]	100	410	8	32	25 Ohm
ABB	GHG 116 9110 V0	no, [ib]	200	640	1.5	5.4	25 Ohm
Pepperl & Fuchs	KHD3-IST/Ex 1	yes, [ia]	130	390	4.2	12.6	60 Ohm
Pepperl & Fuchs	KFD2-STC1-Ex 1	yes, [ia]	130	390	4.2	12.6	60 Ohm
Pepperl & Fuchs	KFD2-CR-Ex1.30-200	yes, [ia]	130	390	4.2	12.6	100 Ohm
MTL	3041 and 5041	yes, [ia]	130	390	4.2	12.6	
MTL	3046B and 5046B	yes, [ia]	130	390	4.2	12.6	

2.3 The 2-wire transmitter Polytron TX

The protection technique of the Polytron TX transmitter is not intrinsically safe, but explosion proof (“d”, flameproof). Therefore an intrinsically safe circuit or safety barrier is not needed.

3

Intrinsic Safety (I.S.) and Safety Barriers

The safety barrier separates the intrinsically safe circuit of the intrinsically safe device from the non-intrinsically safe circuit of the controller. The most basic passive safety barrier contains four essential items:

1. one (or more) current-limiting resistors
2. one (or more) voltage-limiting zener-diodes¹⁾
3. an overload-protection (e.g. a fast acting fuse)
4. a PA/PE ground connector

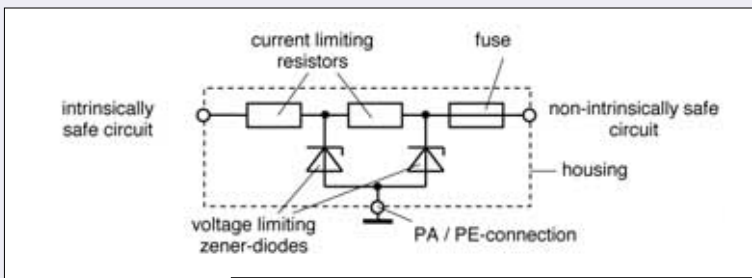

Obviously, such a safety barrier must be approved and marked as an explosion protecting device, e.g. as [EEx ib] IIC. The brackets indicate, that the safety barrier provides an "ib" rated intrinsically safe circuit, however the safety barrier is not an explosion protected device by itself, i.e. it must not be installed in the hazardous area, but in a non-hazardous area (usually in a controller's cabinet).

3.1 Active safety barriers

Since passive safety barriers are only suitable to fuse one conductor of the wiring to ground, two passive safety barriers would be necessary to fuse a ground-floating 2-wire transmitter (like e.g. Polytron 1, Polytron 2 and Polytron L). In principle this is possible (there are ground-symmetric dual-barriers available), however the current-limiting resistors will increase in value, so that the cabling (cable length!) will have significant restrictions.

Functionality:

If the voltage, in case of a fault, of the non-intrinsically safe circuit becomes too high (in reference to PA/PE), the usually high-resistance zener-diodes become conductive and draw such a high current, that the fuse blows. Hence, dangerously high voltages can not get into the hazardous, classified area. If there is a ground-fault in the hazardous area, the maximum current is limited by the current-limiting resistor in the non-hazardous area and/or the fuse blows. Hence, dangerously high currents can not get into the hazardous area, i.e. the power in the intrinsically safe circuit is limited reliably.

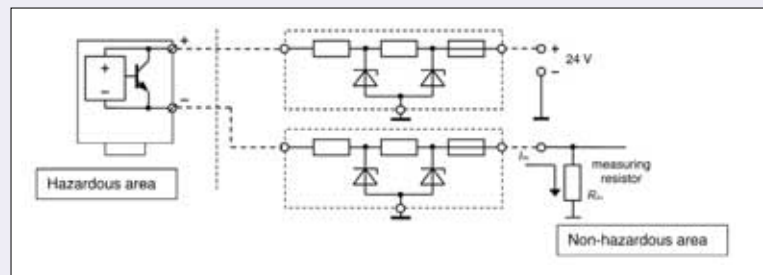

1) Because of the zener diodes safety barriers are frequently called "zener barriers" or "shunt barriers".
The zener diodes are in parallel to the controller input.

Active safety barriers on the other hand are transducers (so-called I.S. transmitter supply units), which pull the 2-wire transmitter to ground and therefore need only one intrinsically safe circuit:

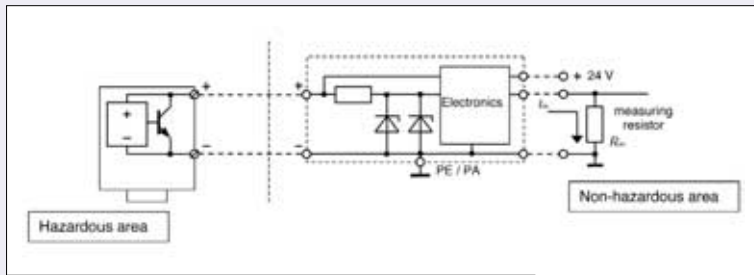

The applied trick is some electronics, which contains a so-called current-mirror.

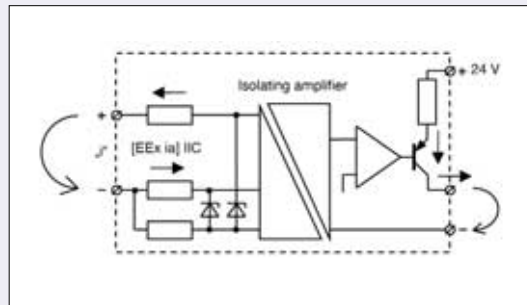
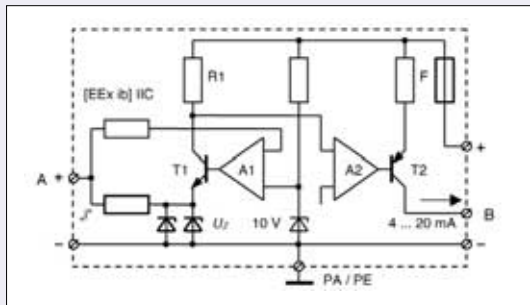

Current mirror:

At the point A (see figure) intrinsically safe and constant 10 V (current- and voltage-limited) are fed in to power the transmitter. If the current coming from point A is changing, the amplifier A1 adjusts the current via transistor T1, so the voltage remains at 10 V. The current is equal to the measuring-current of 4 to 20 mA.

It is measured as voltage drop via R1, and transistor T2 is adjusted by the amplifier A2, so the current output at point B is the same as at point A.

This current mirror is the reason why a transmitter connected to such a safety barrier is drawing more than twice of the measuring current from the 24 V power supply.

3.2 Safety barriers with galvanic isolation

For industrial instrumentation galvanically isolated barriers are preferred. These can be used as intrinsically safe isolation interfaces for 2-wire transmitters and do not need to be grounded (no PA/PE connection).

The characteristics of such I.S. isolated interfaces are one or two buffer-amplifiers, which galvanically isolate (via inductive coupling) the non-intrinsically safe 4 to 20 mA current loop, and, where required, the voltage supply from the intrinsically safe current loop.

3 ■ Intrinsic Safety (I.S.) and Safety Barriers

3.3 Safety relevant data of a safety barrier

In intrinsically safe current loops, the current, voltage and power are limited to defined values I_{\max} , U_{\max} and P_{\max} . Additionally, the cabling has to be taken into account, since its capacity and inductivity act as an energy reservoir which could create sparks if the current loop is opened or closed. Therefore this energy must also be limited and maximum values for the capacity C_{\max} and inductivity L_{\max} are specified. These must not be exceeded. In other words, the allowed cable length between safety barrier and transmitter for intrinsically safe installations is different from non-intrinsically safe installations.

3.4 The installation of a safety barrier

The EN 60079-14 (VDE 0165, 08/98) chapter 12 (additional requirements for the protection technique "i" – intrinsically safe) states about the installation of safety barriers:

- Safety barriers must not be installed in the hazardous area. An IP-rating of at least IP 20 for the installation of safety barriers is required.
- Safety barriers can only be used in electrical installations where the nominal voltage in the cabinet of the central unit does not exceed 250 V (AC or DC).
- The PE/PA-connector of non-isolating safety barriers must be connected to the earth- or common potential bar ("PE/PA") in the hazardous area, otherwise a dangerous potential difference between the signal lines and earth potential can form.

The cables connected to the hazardous area terminals of the safety barrier

- must comply with the max. capacity and inductivity allowed for the chosen safety barrier
- have to be segregated from other (non-intrinsically safe) wirings
- have to be marked as "intrinsically safe circuits". This can easily be done by using blue colored cables.

4 ■ The 2-wire transmitter Polytron 2

One of the main features of Polytron 2 is its ability of digital communication. Electrically it is a so-called FSK-signal²⁾, which is superimposed upon the direct-current signal, with an amplitude of ± 0.5 mA. This way the characteristics of a 4 to 20 mA transmitter is unchanged, however information can be exchanged when an appropriate central controller is used. This communication uses the so-called HART-protocol (see chapter 8).

Another advantage of Polytron 2 is, that the 4 to 20 mA signal can be switched off and only the digital signal (e.g. the current gas concentration) is interrogated by a HART central controller. Then, each transmitter has an individual polling address. This way, up to eight transmitters can be operated on one 2-wire cable (so-called multidrop-mode).

4.1 Polytron 2 in a hazardous, classified area

When used as 4 to 20 mA transmitter, Polytron 2 has to be operated, similar to Polytron 1, with a suitable safety barrier, while certain parameters of the safety barrier have to be taken into account.

These are:

$$U_{\max} = 30 \text{ V}, I_{\max} = 0.3 \text{ A}, \text{ and } P_{\max} = 700 \text{ mW}$$

The values are slightly higher than the ones for Polytron 1, however contrary to Polytron 1, the Polytron 2 transmitter requires a minimum voltage of 16.5 V. Hence not all recommended safety barriers for Polytron 1 may be used for Polytron 2.

The following safety barriers are suitable for Polytron 2:

Manufacturer	Type	U _{max} in V	I _{max} in mA	P _{max} in mW	U in V	Terminals		
						"i"	24 V	4-20 mA
MTL	3041	28	93	651	20 ... 35	5+, 6-	3+, 4-	1+, 2-
Stahl	9303/11-22-11	28	91	637	18 ... 35	7+, 8-	L+, L-	2+, 3-
Pepperl & Fuchs	KFD2-CR-Ex1.30-200	28	93	660	20 ... 35	1+, 3-	11+, 12-	8+, 7-
MTL	3046 B	28	93	651	20 ... 35	5+, 6-	3+, 4-	1+, 2-
Pepperl & Fuchs	KFD2-STC1-Ex1	28	93	660	20 ... 35	1+, 3-	7+, 8-	9+, 10-
Stahl	9303/15-22-11	28	91	637	18 ... 35	7+, 8-	L+, L-	2+, 3-
Stahl	9303/13-22-11	28	91	637	18 ... 35	7+, 8-	L+, L-	2+, 3-

Manufacturer	Type	galvanically isolated	HART	C _{max} in nF		L _{max} in mH		R _{max} per core
				IIC	IIB	IIC	IIB	
MTL	3041 and 5041	yes, [ia]	no	130	390	4.2	12.6	200 Ohm
Stahl	9303/11-22-11	yes, [ia]	no	70	500	4.9	18	350 Ohm
Pepperl & Fuchs	KFD2-CR-Ex1.30-200	yes, [ia]	no	130	390	4.2	12.6	200 Ohm
MTL	3046 B	yes, [ia]	yes	130	390	4.2	12.6	150 Ohm
Pepperl & Fuchs	KFD2-STC1-Ex1	yes, [ia]	yes	130	390	4.2	12.6	150 Ohm
Stahl	9303/13-22-11	yes, [ia]	yes	70	500	4.9	18	200 Ohm
Stahl	9303/15-22-11	yes, [ia]	yes	70	500	4.9	18	175 Ohm

2) Frequency Shift Keying: Digital information is transferred by two fixed frequencies, e.g. 1200 Hz (logic 1) and 2200 Hz (logic 0). The same principle as for well-known fax machines.

5 ■ The 3-wire and 4-wire principle

The biggest power consumer of a 2-wire transmitter is the current loop itself. At full scale at 24 V the power requirement is $24\text{ V} \cdot 0.02\text{ A} = 480\text{ mW}$, while the transmitter electronics needs less than e.g. 50 mW. If the sensor and the transmitter electronics require a significantly higher power for their operation, the 2-wire principle will not work anymore: The transmitter electronics can not be operated parallel to the 4 to 20 mA current interface, because it needs a much higher current than 4 mA.

Only if the transmitter electronics is supplied by a third wire, the 4 to 20 mA current interface can be used in the usual way. Infrared- and catalytic bead transmitters are realized this way, since the sensors and/or the electronics requires more power.

The catalytic bead sensor by itself needs 270 mA at about 3 V, equaling about 800 mW! In this case, a DC/DC converter must be added, which e.g. converts 10 V / 90 mA into 3 V / 270 mA.

The figures below show the different electrical connections of 2-, 3- and 4-wire transmitters.

If a 3-wire transmitter is operated with a 3-core cable, the maximum length of the cabling is, because of the higher voltage drop, much shorter than for 2-wire transmitters. The measuring signal can be transmitted across a greater distance. Therefore the signal cable is separated from the supply cable and operates the transmitter on two 2-wire cables (so-called 4-wire operation). For this, a second cable gland has to be installed.

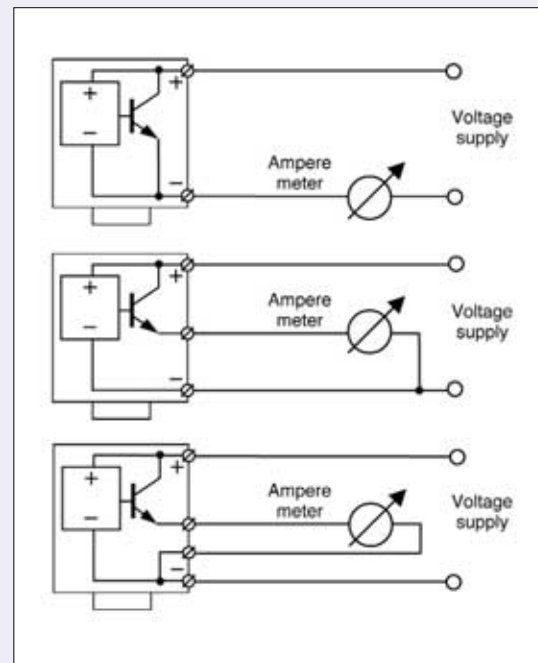

The electrical connection of a 3-wire transmitter (e.g. Polytron Ex, Polytron IR Ex or Polytron 2 XP) is shown in the following figure:

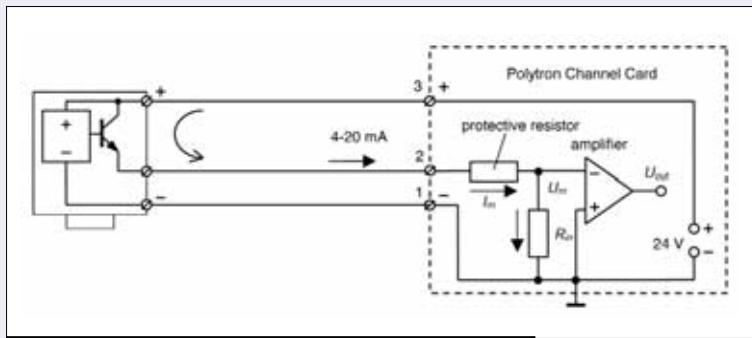

If a Polytron Ex transmitter is operated with 24 V, and a current of 150 mA is flowing, the voltage drop across the two 20 Ohm resistors (representing the resistance of the cable) is 3 V each. The current-transistor has a maximum of 7 V available in order to generate a 20 mA signal at maximum load resistance. Hence the maximum load resistance for the 4 to 20 mA signal is $7\text{ V} \div 0.02\text{ A} = 350\text{ Ohm}$.

Using the Polytron Channel Card, which has a high impedance (200 Ohm input- resp. protective-resistance), with 4-wire connection technique the 4 to 20 mA signal line may have a resistance of up to 75 Ohm per core (e.g. 4 km at 1 mm² cross-section).

The 3-wire connection allows even 480 Ohm load resistance, because the voltage drop across the 20 Ohm return resistance is an additional $20\text{ Ohm} \cdot 0.13\text{ A} = 2.6\text{ V}$, and for the generation of the 20 mA signal there are 9.6 V instead of 7 V available. The maximum load resistance is calculated as $9.6\text{ V} \div 0.02\text{ A} = 480\text{ Ohm}$.

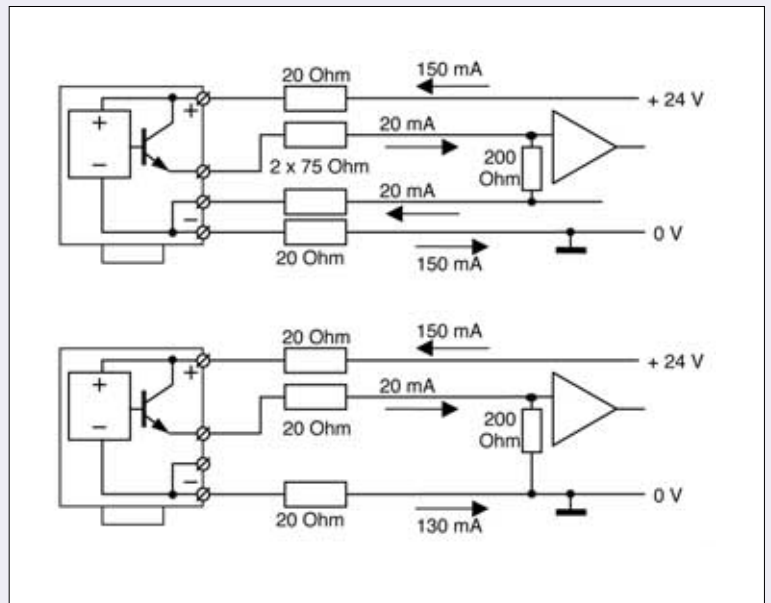

6 ■ The Polytron 3-wire transmitters

6.1 Polytron FX

Polytron FX is an explosion proof ("d") 3-wire transmitter in protection type EEx d IIC T6. It can be operated between 16 and 30 V, and draws at 24 V about 90 mA. The transmitter has to be connected to a sealed conduit or has to be installed with an explosion proof seal/cable gland (EEx d).

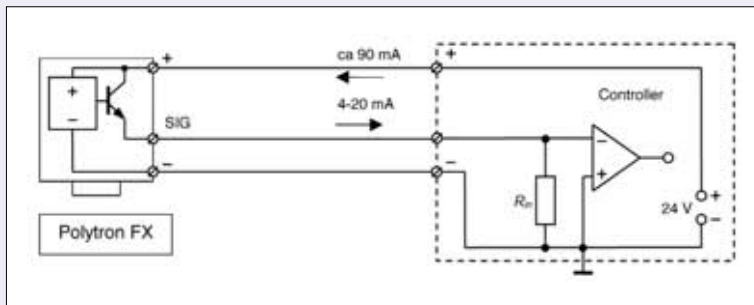

6.2 Polytron Ex

Concerning the protection concept EEx me [ib] IIC T4 of Polytron Ex, it has to be mentioned that the transmitter has, in part, an intrinsically safe electronics (potentiometers, LC-Display with circuit board, sensor connection), however it can not be operated using a safety barrier or connected to an intrinsically safe circuit. This is indicated by the brackets in the certification code.

The necessary current- and voltage-limiting parts and fuses are contained within the transmitter, and are protected with the protection type 'm' (moulded). As to say, the necessary safety barriers are built into the transmitter and provide intrinsically safe circuits. For example, the voltage U , current I and the power P for the connection of the catalytic bead sensor are limited to:

$$U_{\max} = 6.2 \text{ V}, I_{\max} = 812 \text{ mA}, P_{\max} = 4.0 \text{ W}$$

The intrinsic safety of all non-moulded circuits allow to open the transmitter during operation, to calibrate and even to change the sensor – with one important exception: Since the connection of the transmitter to the central controller is not intrinsically safe, it is realized in a separate terminal-compartment with Ingress Protection IP 54 and an approved cable gland. This compartment may only be opened for maintenance purposes, if a hot-work-permit has been issued, or it can be ensured by other means, that no combustible atmosphere can develop (e.g. by using a suitable portable gas detection instrument).

The remote transmitter Polytron Ex R (R = remote) is equipped with a 10 m, 3-core cable to connect a catalytic bead sensing head (e.g. SE Ex PR M). The cable must not be extended because of explosion protection requirements. The explosion protection is EEx me [ib] IIB T4, meaning that it is not allowed to have the transmitter operated in atmospheres containing hydrogen.

6.3 Polytron IR Ex

The Polytron IR Ex transmitter and all its versions have a similar design (while the infrared source is explosion proof "d"):

EEx em [ib] d IIB+H2 T4.

All non-moulded circuits are intrinsically safe and protected by parts covered by potting (e.g. resistors, zener-diodes and fuses). The sensor connection, the connector for the hand held terminal, key pad and the LC-display with circuit board are intrinsically safe. The enclosure of the transmitter may be opened during operation, however never the separate terminal-compartment (EEx e)!

The maximum load resistance for 3-wire (450 Ohm) and 4-wire (350 Ohm) connection is the same as for Polytron Ex. However, because of its higher power consumption Polytron IR Ex requires a higher minimum voltage of 13 V, and the resistance of the wiring may not exceed 22 Ohm per core at 24 V.

Different versions of the IR Ex transmitter are available:

For transmitters which are easily accessible to the operator:

Polytron IR Ex, complete with display and keypad. The transmitter is operated directly via the built-in display and keypad.

Polytron IR Ex NDH, non-display with socket for hand held terminal. The transmitter is operated via the hand held terminal using the plug connection.

Polytron IR Ex

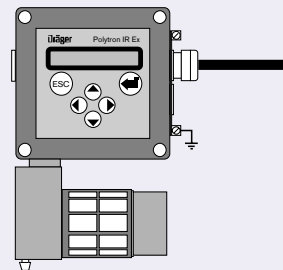

Polytron IR Ex NDH

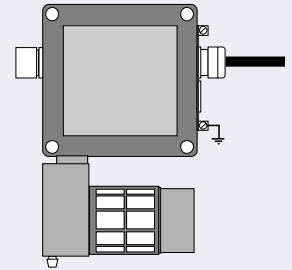

For transmitters which are not easily accessible to the operator:

Polytron IR Ex NDF, non-display and remote display unit. The transmitter is operated via the display and keypad of the remote display unit. The 3-core cable between remote display unit and transmitter is intrinsically safe and must not be longer than 30 m. The remote display unit is intrinsically safe: EEx ib IIC T4.

Polytron IR Ex NDF, non-display with IR junction box and socket for hand held terminal. The transmitter is operated via the display and keypad on the hand held terminal. The 3-core cable between junction box and transmitter is intrinsically safe and must not be longer than 30 m. The hand held terminal is intrinsically safe: EEx ib IIC T4.

Polytron IR Ex NDF

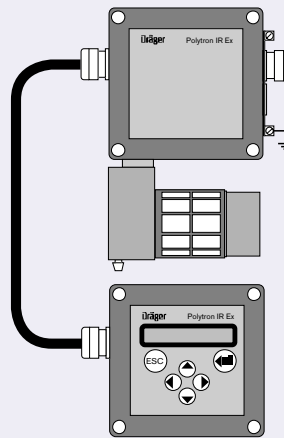

Polytron IR Ex NDF

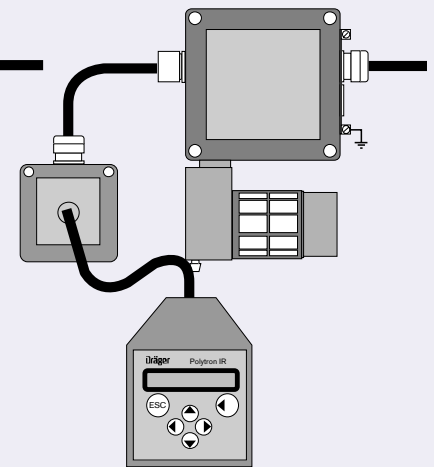

6.4 Polytron IR, Polytron 2 XP Ex and Polytron 2 XP Tox

A new generation of 3-wire transmitters is represented by Polytron IR, Polytron 2 XP Ex and Polytron 2 XP Tox. They are explosion proof (“d”) and offer additional to the 4 to 20 mA current interface also the possibility of an addressable digital communication via HART or RS 485.

3-wire transmitters	Supply voltage	Current
Polytron FX	16 ... 30 V	90 mA @ 24 V
Polytron Ex	10 ... 30 V	90 mA @ 24 V
Polytron IR Ex	13 ... 30 V	
Polytron IR	15 ... 30 V	
Polytron 2 XP Ex	10 ... 32 V	180 mA
Polytron 2 XP Tox	10 ... 32 V	120 mA

7 ■ Polytron transmitter and programmable logic controller systems

In principle, all 4 to 20 mA transmitters can be connected to any programmable logic controller (PLC, e.g. Siemens SIMATIC), if these have a 4 to 20 mA input module, can supply the necessary power and the software can interpret the 4 to 20 mA signal:

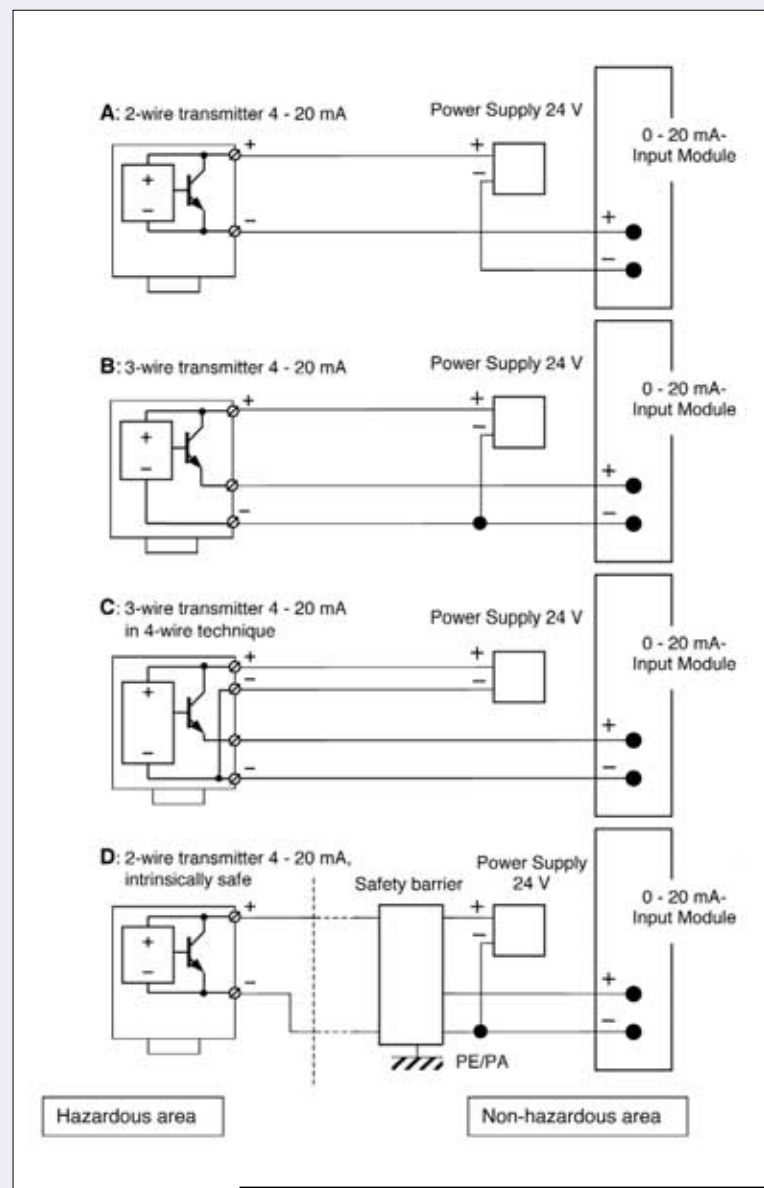

8 Digital Communication

The essence of digital communication is the addressability of the "participants". By sending an address-command, the sender (master) can communicate with one of many receivers (slaves), connected to the bus, and exchange data with them. The simplest version would be, that the master sends a special code following the address command, which is interpreted and executed by the software of the receiver. In case of serial data transfer (RS 485), a 2-wire cable is needed for the power supply and a twisted pair for the digital communication. However, if a transmitter should communicate digitally via the power supply cable, the digital information is superimposed as a frequency-modulated signal on the supply voltage. This is the so-called HART communication.

8.1 HART Communication

The digital communication with a HART-capable transmitter requires certain conventions between sender and receiver. For example, a receiver must recognize that a request for information has been sent, must understand the question and must send the proper answer to the inquirer. For this, a special software is necessary. In case of the HART-communication it is the so-called HART-protocol.

The concept of the transmitter Polytron 2 not only implies an I²C-bus for data exchange between sensor and transmitter electronics but also for the bidirectional digital communication between transmitter and a capable central controller without affecting the 4 to 20 mA signal characteristics. For this purpose HART³⁾ communication is widely accepted in industrial applications.

HART communication can be performed in two different ways:

- With the well-known point to point cabling the well-known 4 to 20 mA signal is superposed by a frequency modulated signal which can be used for bidirectional data exchange between a HART-transmitter and HART-capable central controller or hand held terminal.
- With the multidrop-wiring the 4 to 20 mA signal is switched of and several transmitters can be operated on a single 2-wire cable. Bidirectional data exchange is only possible by the frequency modulated signal. In this case transmitters have digital addresses, which are used by a HART-capable central controller or hand held terminal to select only one of several transmitters at a time.

The frequency modulated signal⁴⁾ is an alternating current with an amplitude of ± 0.5 mA, the frequency of which is 1200 or 2200 Hz for logic 1 resp. 0. The mean value of the sine-shaped signal is zero so that the 4 to 20 mA signal is not influenced. This is the so-called 'Bell 202 Standard', the well-known sound of fax-machines. The figure shows the 8-bit-information '10110100' which is hexadecimal \$B4, or decimal 180:

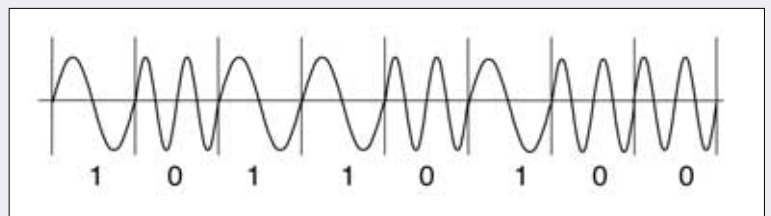

The HART-signal can be transformed to a standardised serial signal (e.g. RS 232) by means of a special modem and can be used by computers and programmable logic controllers etc. However several communication parameters have to be considered so that the RS 232 interface is able to understand the HART data. Configuration should be as follows:

Data rate: 1200 Baud (bits per second), 1 start bit, 8 data bit, 1 stop bit, parity odd

3) HART = Highway Addressable Remote Transducer

4) FSK-Signal = Frequency Shift Keying

2-wire and 3-wire transmitters with HART communication

As an example using Polytron 2 and Polytron IR the picture shows the wiring of 2-wire and 3-wire transmitters to communicate via HART-protocol⁵⁾. The load resistor shown is optional and only necessary if the input resistance of the HART-capable central controller is lower than 230 Ohm.

If a Polytron 2 transmitter has to be operated in a hazardous, classified area, a HART-capable safety barrier must be used. Similar to a 3-wire transmitter the non-intrinsically safe side of the safety barrier is connected to the HART-capable central controller.

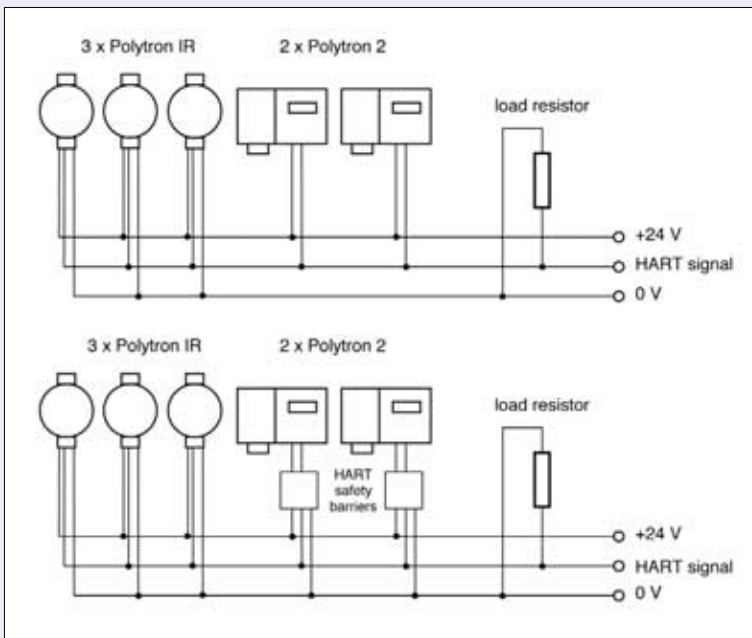

5) This is only the principle wiring. Voltage drops along the power supply cables have to be carefully considered as well as a sufficiently dimensioned power supply.

HART-Communication Software

Having met the necessary physical (hardware) requirements the master (a HART-capable central controller) can send an addressed command to the slave (e.g. a Polytron 2 or Polytron IR transmitter). Two masters are allowed: A primary master (central controller) and a secondary master (hand held terminal).

HART communication is 'half-duplex', this means after having transmitted a command the master switches into the receive mode. If the master is not sending a command, it always listens.

The communication software is not described here.

8.2 RS 485 Communication

The RS 485 is a high-speed bidirectional digital communication bus system to communicate over long distances with up to 32 addressable participants. Since there is more than one sender connected to a single communication line it has to be ensured by a protocol that only one sender is active at a time (half-duplex). This protocol also regulates the addressing of the devices, monitors the correctness of the received data and ensures proper timing.

The serial data are transferred as a voltage difference (floating) between two corresponding cables. The RS 485 sender produces a signal of ± 2 V. If the voltage difference is lower than 300 mV the receiver recognizes a logic 1. If the difference is higher than 300 mV it corresponds to a logic 0. During installation the correct polarity of the two wires must be considered, otherwise the data signal is logically inverted and misinterpreted.

9

Cables, resistance and characteristics

Resistance of a copper cable with given cross-section

Cross-section	0.5 mm ²	1.0 mm ²	1.5 mm ²	2.5 mm ²	4.0 mm ²
Resistance	36 Ohm/km	18 Ohm/km	12 Ohm/km	7.2 Ohm/km	4.5 Ohm/km

The table above shows the resistance of a copper cable with a given cross-section. This can be calculated by

$$R_{\text{core}} = \frac{L}{A} \cdot \rho_{\text{Cu}}, \text{ with } \rho_{\text{Cu}} = 0.018 \frac{\text{Ohm} \cdot \text{mm}^2}{\text{m}} \text{ or } 1.8 \cdot 10^{-6} \text{ Ohm} \cdot \text{cm}$$

where ρ_{Cu} is the specific resistance of copper at 20°C. At higher temperatures this resistance is increased by 0.4 % per degree. L is the cable length in m and A is the cross-section in mm².

Typical cable data (cross-section 1 mm²)

Cable resistance:	R = 18 Ohm/km
Cable capacity:	C = approx. 155 nF/km
Cable inductivity:	L = approx. 0.67 mH/km

American Wire Gauge

The American Wire Gauge is a world wide used logarithmic measure for cable cross-sections. The cross-section can approximately be calculated by the formula

$$A = 50 \cdot 10^{-\lambda}, \text{ where } \lambda = \frac{\text{AWG}}{10}$$

The cross-section is obtained in mm².

20 AWG corresponds to roughly 0.5 mm². Industrial instrumentation and electronics are mostly based on AWG 20 up to AWG 12.

The cross-section of a protective earthing cable (PE-connection) mostly is required to have 10 AWG corresponding to a cross-section of 4 mm².

Frequently used AWGs in industrial instrumentation

AWG	AWG 20	AWG 18	AWG 16	AWG 14	AWG 12
cross-section	0.510 ... 0.620 mm ²	0.816 ... 0.969 mm ²	1.237 ... 1.442 mm ²	1.95 ... 2.23 mm ²	3.10 ... 3.65 mm ²
medium cross-section	0.57 mm ²	0.89 mm ²	1.34 mm ²	2.10 mm ²	3.38 mm ²
medium resistance	32 Ohm/km	21 Ohm/km	14 Ohm/km	8.6 Ohm/km	5.5 Ohm/km

10. The Polytron Sampling Unit

The sampling unit is a small yet powerful pump module, which is housed in a Polytron 2 enclosure. When using the sampling unit, it is possible to sample the gas/air mixture which needs to be monitored from areas which are not easily accessible, or where it is not possible or allowed (e.g. sometimes in clean-rooms) to install a Polytron transmitter. The sampling unit needs 24 VDC for operation and can be connected to a central controller system in five different ways.

The main components of the sampling unit are: dust filter, flow control, electronics, wheel-pump (see figure) and flow-switch. With an inner diameter of the tubing of 4 mm, the length of the sampling tubing can be some centimeters up to more than 20 meters.

Motor-driven wheel pump

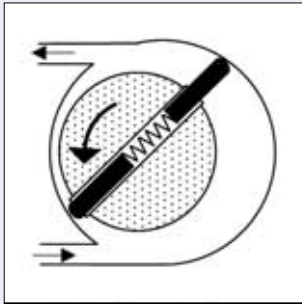

The flow depends on the supply voltage and is adjustable between 0.5 liters/min. and 1.5 liters/min., using a potentiometer. The factory set flow is 0.5 liters/min.

Supply voltage	Power consumption	Flow
10 to 30 V DC	< 2 W	0.5 liters/min.
15 to 30 V DC	< 4 W	1.0 liters/min.
20 to 30 V DC	< 6 W	1.5 liters/min.

Depending on the length of the sampling line, the response time may increase considerably. At a flow of 0.5 liters/min. and reasonable sampling lengths (e.g. 20 m, inner diameter 4 mm) the response time is increased by about 30 seconds. Furthermore adsorption effects on the sampling tube's surfaces can cause problems. Sampling air containing carbon monoxide (CO) is without any problem whereas traces of chlorine (Cl₂) or hydrogen sulfide (H₂S) might be adsorbed and will not be detected. Also, temperature gradients and condensation of humidity must be considered.

Sampling without flow-monitoring is not safe!

The main concept of the sampling unit is easy wiring. The sampling unit and the connected 2-wire or 3-wire-transmitters are operated by the same supply voltage. It is very essential to monitor the flow by a reliable flow contact⁶⁾, which usually needs additional wiring. If, however, the flow-alarm is generated by shortening the 4 to 20 mA signal, no additional wires are needed. In case of failure the signal is less than 4 mA and indicates a failure.

The following calculation shows that especially at higher cables resistances the shortening ("shunting") of a low-resistance 4 to 20 mA input can cause problems (s. figure):

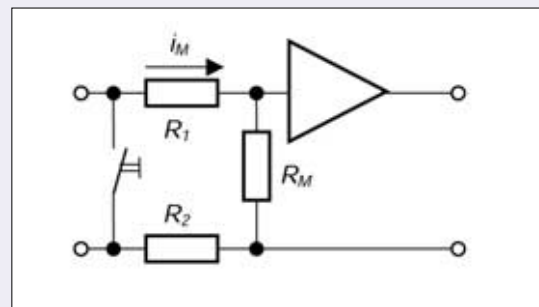

6) If the sampling pump is not running, the gas sensor cannot monitor the gas concentration and the reading is zero although there might be a high gas concentration!

During normal operation, the signal current i_M flows through the resistors R_1 and R_M . If the switch is closed the current i_M is reduced by the current flowing through the resistor R_2 . The signal current i_1 then is reduced to

$$i_1 = \frac{R_2}{R_1 + R_2 + R_M} \cdot i_M$$

Example:

Input resistance $R_M = 50 \text{ Ohm}$, cable length $L = 347 \text{ m}$ between sampling unit and central controller (cross-section $A = 0.5 \text{ mm}^2$), with $\rho_{Cu} = 0.018 \text{ Ohm} \cdot \text{mm}^2/\text{m}$, the cable resistance $R_1 = R_2$ is calculated as:

$$R_1 = R_2 = \frac{2 \cdot \rho \cdot L}{A} = \frac{2 \cdot 0.018 \cdot 347}{0.5} = 25 \text{ Ohm}$$

A closed flow contact will not produce a real shortening, but will reduce the signal current to a quarter of the original current:

$$i_1 = \frac{R_2}{R_1 + R_2 + R_M} \cdot i_M = \frac{25}{25 + 25 + 50} \cdot i_M = \frac{1}{4} \cdot i_M$$

If there is no gas (output signal 4 mA) a flow-failure will change the output signal to 1 mA and the failure can be recognized reliably. What about oxygen monitoring? A 4 to 20 mA transmitter with a measuring range of 25 Vol% O_2 , exposed to ambient air, produces a signal of 17.4 mA. In case of a flow failure the signal current would be 4.35 mA, which is not sufficient to be recognized as a failure, it will only be recognized as an oxygen deficiency alarm.

In order to have a reliable flow monitoring the resistor R_2 must be considerably lower than R_1 plus R_M :

$$R_2 \ll R_1 + R_M$$

Since R_M is fix, the sampling unit provides an additional switchable 150 Ohm resistor so that R_1 can be increased if necessary.

The figure shows the essential elements of the sampling unit. On the left side a 2-wire or 3-wire transmitter can be connected, on the right side the central controller (power supply and 4 to 20 mA input) is installed. When the supply voltage is switched on, the relay is energized and the 'power on' NC contact closes so that the 4 to 20 mA signal of the transmitter can pass to the controller. The flow is monitored by a differential pressure switch with a flow-contact (NO).

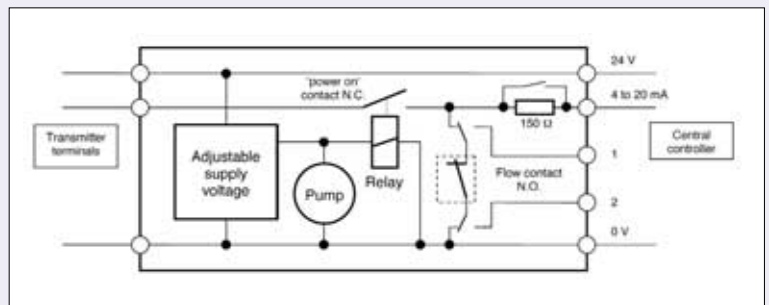

Depending on the configuration, the flow-contact can also be used as a voltage-free contact between terminals 1 and 2. The 150 Ohm resistor is normally bridged.

If, however, the flow is too low the flow contact closes and the 4 to 20 mA signal is shortened. This is interpreted as a fault alarm in the central controller, as long as it is ensured that the cable resistance is not higher than 1% of the controller's input resistance.

10 ■ The Polytron Sampling Unit

The sampling unit is suitable to be operated in 5 different modes (refer to the following picture).

1. Sampling unit with 2-wire transmitter: This shows how a 2-wire transmitter can be used with the sampling unit. Cable resistance requirement: $R_2 < R_M / 100$, e.g. if the input resistance R_M is 250 Ohm, the cable resistance R_2 must not be higher than 2.5 Ohm.

2. Sampling unit with 2-wire transmitter: If the input resistance R_M of the controller however is low, e.g. 50 Ohm only, the 150 Ohm resistor can be activated to fulfill the above cable resistance requirement. With this resistor we have: $R_2 < (R_M + 150) / 100$, e.g. if the input resistance R_M is 50 Ohm, the cable resistance R_2 must not be higher than 2 Ohm. Of course it has to be considered that the 4 to 20 mA loop resistance now has increased by 150 Ohm.

3. Sampling unit with 3-wire transmitter: In this case four wires have to be installed between sampling unit and central controller unit. This installation requires $R_1 + R_3 < R_M / 10$, e.g. if the input resistance is 250 Ohm it must be ensured that $R_1 + R_3$ are lower than 25 Ohm.

4. Sampling unit with 3-wire transmitter and grounded flow contact. This configuration is suitable to have a flow alarm separately, e.g. to switch a customer's relay at the controller side. The max. ratings of the contact have to be considered: $U_{max} = 30 V$, $i_{max} = 500 mA$, $P_{max} = 10 W$, for ohmic loads only.

5. Sampling unit with 2-wire transmitter (not suitable for 3-wire transmitters) and voltage-free flow contact e.g. to switch a customer's relay at the controller side. The max. ratings of the contact have to be considered: $U_{max} = 30 V$, $i_{max} = 500 mA$, $P_{max} = 10 W$, for ohmic loads only.

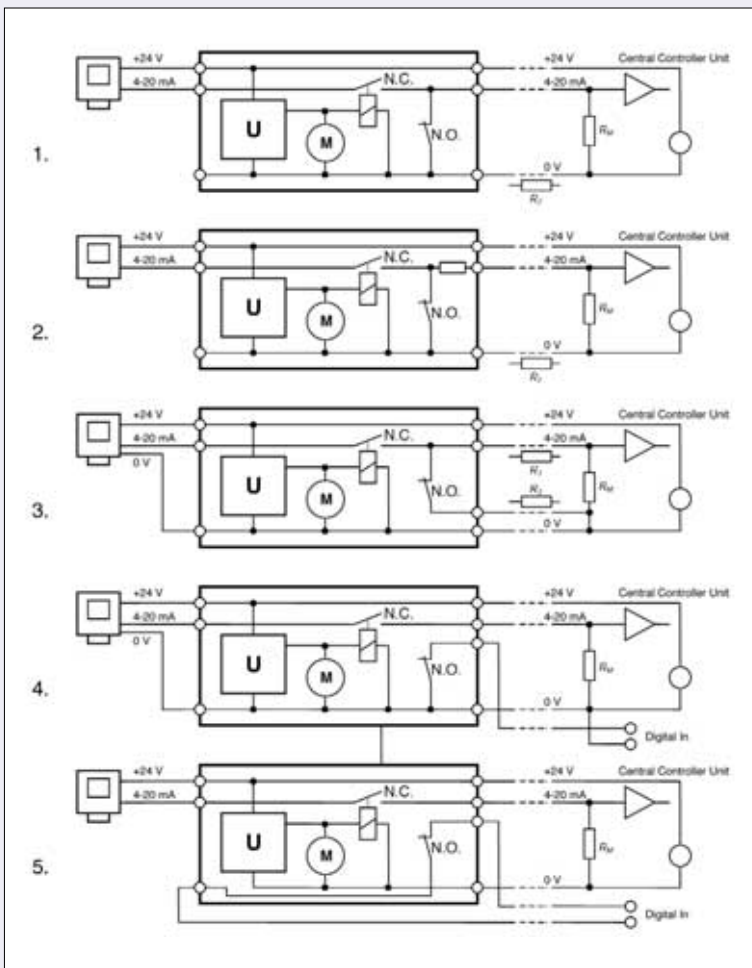

Dräger Safety AG & Co. KGaA

Revalstrasse 1
D - 23560 Luebeck
Germany
Tel. + 49 451 8 82 - 27 94
Fax + 49 451 8 82 - 49 91

Draeger Safety UK Ltd.

Ullswater Close
Kitty Brewster Industrial Estate
Blyth, Northumberland, NE24 4RG
United Kingdom
Tel. + 44 1670 352891
Fax + 44 1670 356266

Draeger Industrie S.A.

3c, Route de la Fédération
F - 67025 Strasbourg Cedex
France
Tel. + 33 388 407676
Fax + 33 388 407667

Draeger Safety, Inc.

505 Julie Rivers
Suite 150
Sugar Land, TX 77478-2847
USA
Tel. + 1 281 498 1082
Fax + 1 281 498 5190

Draeger Safety Asia Pte Ltd.

67, Ayer Rajah Crescent #06-03
SGP-139950 Singapore
Singapore
Tel. + 65 872 9288
Fax + 65 773 2033

Beijing Fortune Draeger Safety Equipment Co., Ltd.

22 Yu An Rd., B Area
Beijing
Tianzhu Airport Industrial Zone
Shunyi County
Beijing, 101300
P.R. China
Tel. + 86 10 80498000
Fax + 86 10 80498005

DrägerService

Dräger equipment must always be fully operational and safe. DrägerService offers a regular inspection service and is quickly available in the event of malfunction. Your equipment will be repaired and back in operation as quickly as possible. Dräger-Service facilitates the vital flow of information between client and manufacturer.

Dräger Expertise

Since 1889, Dräger has had an outstanding reputation for solving problems in the field of human breathing. Dräger has been deeply involved in the handling of gases, in particular hazard protection and the saving of life in medical and industrial emergencies. Many of the company's 9500 employees are active in research and innovation to ensure that the latest techniques and scientific advances are fully tested before their inclusion in new equipment.



Dräger Worldwide

The Dräger sales and service organisation is spread throughout the world. It comprises more than 25 subsidiaries and associated companies to ensure that Dräger is always within easy reach of its clients and in close contact with all important markets. Dräger's ever increasing market share demonstrates the company's international competitiveness and strength.

Dräger has subsidiaries in the following countries: Australia, Austria, Belgium, Bulgaria, Canada, China, Croatia, Czech Republic, Denmark, France, Great Britain, Hungary, Indonesia, Italy, Japan, the Netherlands, Norway, Romania, Singapore, Slovenia, Slovakia, South Africa, Spain, Sweden, Switzerland, Thailand, Yugoslavia, USA. Additionally, Dräger is widely represented in Central and South America, Africa, the Middle East, the Far East and Eastern Europe.

Visit us at:
www.draeger-safety.com/gds

Represented by:

Quality and Environmental Management

Our mission includes the continuous improvement of our Quality and Environmental Management Systems in accordance with ISO 9001 and ISO 14001.